A Highly Selective 8th Order Band-Pass Filter for Lightning Remote Sensing Applications

TAHA RAAD AL-SHAIKHLI¹, MUSTAFA MURTDHA AL-SAEEDI², ABDULNISER KHALD HAMZAH¹, MOHD RIDUAN AHMAD³, BADRUL HISHAM AHMAD³, USAMA S. AL-TIMARI¹

¹Department of Computer Engineering Techniques, Al-Nisour University College, Baghdad, Iraq

² Department of media technology engineering, University of information technology and communication, College of engineering.

³Atmospheric and Lightning Research Lab Centre for Telecommunication Research and Innovation (CeTRI), Fakulti Kejuruteraan Elektronik dan Kejuruteraan Komputer, Universiti Teknikal Malaysia Melaka (UTeM), Malaysia.

Email: taha.r.eng@nuc.edu.iq

Abstract: Recently, it has been discovered there was an emission of microwave radiation in advance of the lightning process. Therefore, a lot of researches focus on designing alarm systems that can detect and analyze these radiated signals. The previous designs based on commercial band-pass filters which have low accuracy factor and quite expensive as well as the detected signal were tiny in amplitude, thus higher efficiency filters are needed with a flat frequency response for passed band frequencies between 950 MHz to 1050 MHz in order to avoid the GSM band which generates a high interference to the mentioned detection system. In this research, a band-pass filter has been designed and tested for measurement with a center frequency of 1 GHz and by using Advance Design System (ADS) to be simulated and then fabricated on FR-4 substrate. The measurement came with good compatibility to the simulation results at return loss of -34.747 dB and also the insertion loss of -3.83 dB. This design also works perfectly for the Lightning detection sensor of Narrow Bipolar Event (NBE).

Keywords: Lightning detection sensor of Narrow

INTRODUCTION

Filters are key components for communication systems nowadays especially microstrip filters because it is a low profile filters and their ability to cover higher frequencies (microwave signals). Band-pass filters are types of filters that can allow a band of frequencies to be pass through its circuitry and suppressed the signals of other frequencies, the passband boundaries based on the filter specifications. A critical issue of choosing the right filter type at the frequency ranges of gigahertz is the impossibility to use lumped elements for such frequencies. Therefore a microstrip solution has been chosen which provides a compact design, easy to be integrated with other circuits such as amplifiers, and the ability to use different substrates in order to get different frequency responses. The major methods involved in the microstrip designs have Parallel coupled microstrip lines, stub lines, and Stepped impedance resonators. parallel coupled lines in microstrip filters can produce high-quality factor filters while stub lines used to produce broadband filters.(Al-Amin, Omar, & Chowdhury, 2016)(Al-Shaikhli et al., 2018)

Filter structures important frequency in RF and Microwave applications such as Satellite, mobile communication and microwave communication including systems, the microwave filter structures performance, such as small size and low price it is desirable to meet the requirements. High speed wireless local area networks (LAN) and global services such as positioning systems (GPS) and Bluetooth, which is concerned as Interoperability for microwave access (WiMAX) systems and Industrial science and medical (ISM) Systems at frequencies between 900 MHz to 6 GHz apply.(Moitra, Nath, Rout, & Bhowmik, 2017)(Verma, Srivastava, & Engineering, 2015).

One of the ways to meet this need is the application to use for microwave filters. Most common preferred planar structure, manufactured in miniature sizes as well as high performance microstrip structures. Performance band for many applications intercepting loss level and selectivity filter Evaluate, for high performance and low loss, low selectivity as well as many applications in the flag significant delay in obtaining group delay bears. A dual transmission zero microstrip filters concerned to designing high performance structures which they are suitable for transmission, filter depending on the configuration of the structure whether real or virtual finite frequencies may be formed. Wireless communication systems and band pass filter is very important for filtering an important frequency.(Taghizadeh, Moloudian, & Rouzbeh, 2015)

Lightning is the natural sudden electronic discharge that happened occurs typically during the thunderstorm. This natural discharge occurs normally between electrically charged regions of a cloud (called intra-cloud lightning or IC), the other type between two clouds (CC lightning), or between a cloud and the ground (CG lightning). Most of lightning occurs within the cloud called intra-cloud (ICs) discharges. But it can also occur between different clouds called cloud-to-cloud (CCs) and most common occur between cloud-to-ground (CGs) lightning discharges. (Ahmad, Esa, Cooray, & Dutkiewicz, 2014) The foxing on cloud-to-ground (CG) lightning has been studied more than the other types of lightning because its more dangers on the human been (Moore, 2015).

Band Pass filter (BPF)

The band-pass filters are filters that allow a band of frequencies to pass and reject unwanted bands. They are used widely in wireless receivers as well as transmitters. The use of filters in the wireless transmitters is to limit the output band to the allocated band for transmission. (Chen & Liao, 2016) that will guarantee there will be no interference with other adjacent frequencies and to get rid of harmonic signals. On the receiver side, the use of BPF is to passes a selective frequency or band of frequencies for transmission to be decoded by other components of the receiver and suppressing the unwanted signals from other transmitters, and BPF has a good ability to optimize the signal to noise ratio to increase the system sensitivity. (Vaghela, Sisodia, & Prabhakar, 2015)

Well-designed BPFs in both transmitters and receivers systems will have an optimized response for mode and speed of communication, increasing the number of transmitters and minimize the number of interfering signals. (Al-Amin et al., 2016)

Data and methodology

I.1. Band Pass Filter design

The proposed BPF was designed single band by using maximally flat lumped element filter circuit topology with resonance frequency from 0.8 GHz to 1.2 GHz, is shown in Figure 1. This conventional topology needs the relatively large inductance and small capacitance values. It causes its performance degraded due to large inductor area and unwanted EM coupling in 3D filter structure. (Garg, Pratap, & Gupta, 2016).

J-inverter then is used to transfer the resonator from serial type to shunt ones to avoid unwanted EM coupling in structural design. Then parallel-series type topology shows in Figure 1 is changed to its equivalent circuit shows in Figure 2.

The circuit can be characterized by the following frequency dependence of input admittance, where ω_0 is the resonance frequency, and ω_p is the zero frequency, which given as follows

$$B_L(\omega) = \frac{1}{\omega(L_1 + L)} \cdot \frac{\frac{\omega^2}{\omega_0^2} - 1}{\frac{\omega^2}{\omega_D^2} - 1} \tag{1}$$

$$\omega_0 = \frac{1}{\sqrt{L_2 C_2}}, \omega_p = \frac{1}{\sqrt{L_s + C_1}} \tag{2}$$

$$L_s = L_1 L / (L_1 + L) \tag{3}$$

The design of Band Pass Filter is 8th order operating frequency from 950 MHz to 1050 MHz by using ADS (Advance Design System) software as show in figure 1:

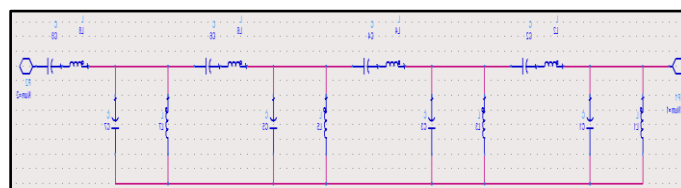

Fig.1: The schematic of band pass filter design.

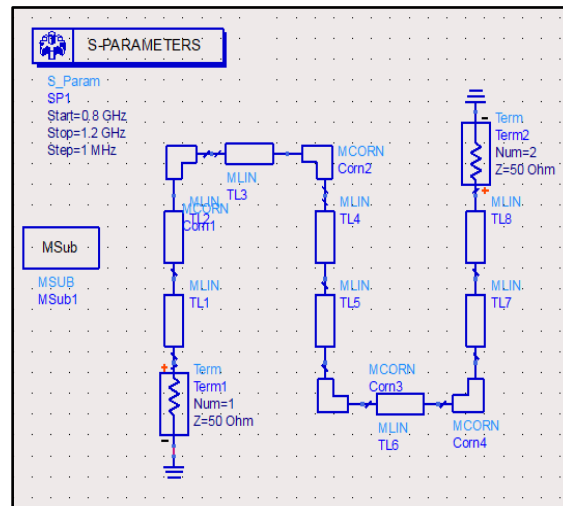

Fig.2: The schematic of lumped Band Pass Filter.

RESULTS AND ANALYSIS

1.1 Band pass Filter results

The Band Pass Filter designed by ADS software with 8th order as showed in figure 3, to give more linearity and stability for the band pass filter and make it near to rectangular pulse, which can be achieve by increasing the number of orders. Table 1 showed the results of the simulation BPF parameters.

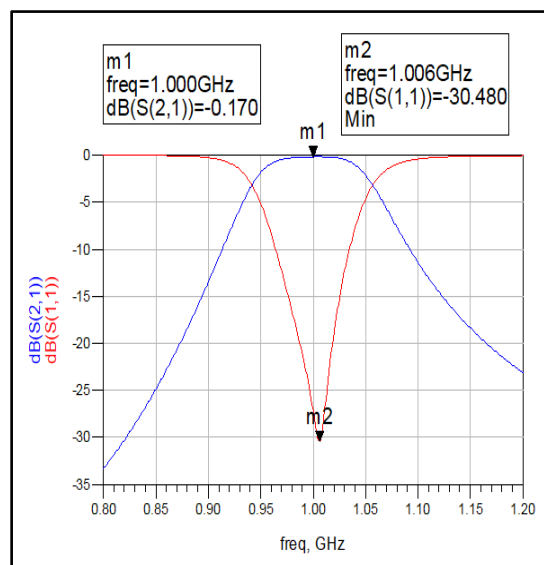

Fig.3: The ADS S-Parameters results of the Band pass filter value.

Table 1: the results of Simulation design Band Pass Filter (BPF) value.

Parameter	Value
Frequency rang	800 MHz – 1200 MHz
Operating Frequency	950 – 1050 MHz
Bandwidth	100 MHz
S (2,1), gain	-0.17 dB
S (1,1), Return loss	-30.48 dB

For proceeding to fabrication, the schematic design must transfer to layout shape by ADS to git the momentum results first before the fabrication which giving more closest results to the reality, shows in figure 4:

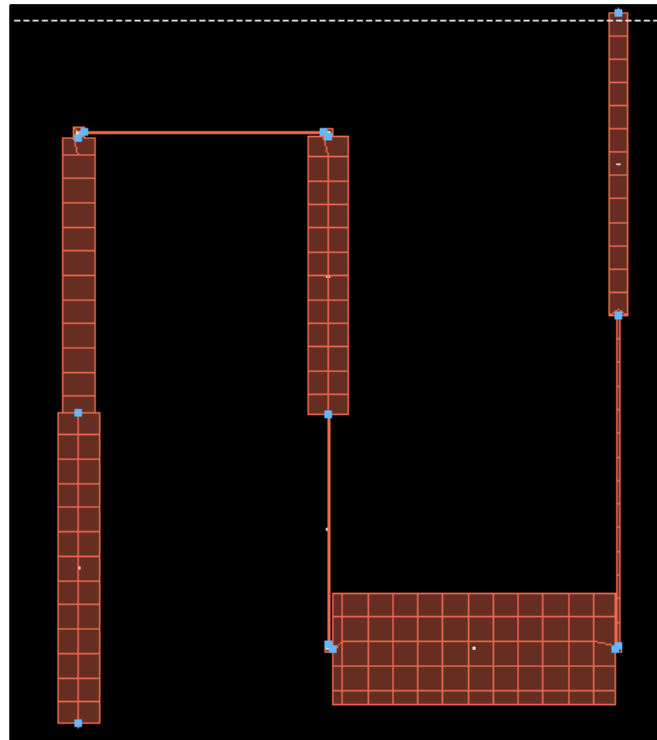

Fig.4: Layout response of Band Pass Filter

I.2. Experiment results

The final design done by using computer aid with software of “Advanced Design System” (ADS) and the produced layout printed on “FR-4” substrate of dielectric constant of $\epsilon_r = 4.7$ and thickness of 1.6 mm, copper thickness is 0.035 mm and tangent loss 0.0009. the resonate frequency designed to be at 1 GHz. As shown in figure 5:

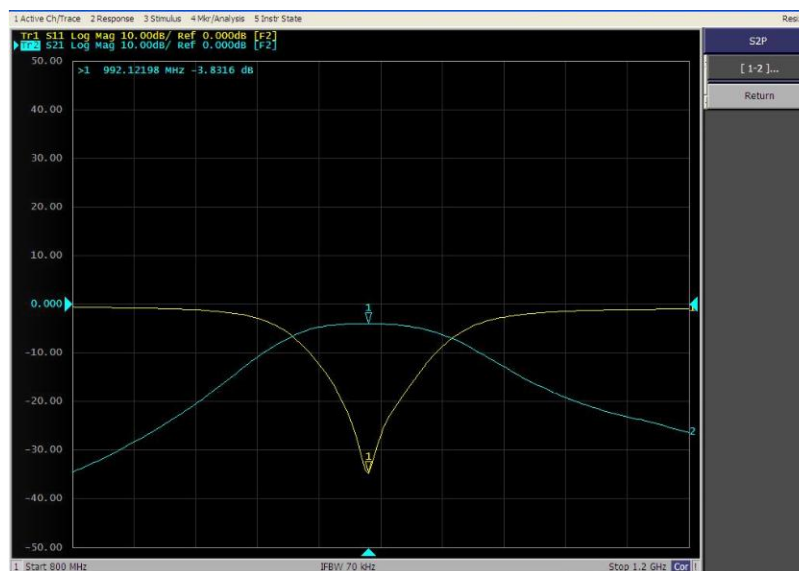

Fig.5: The fabrication experimental results for Band Pass Filter

The experimental results shows the S- parameters (S₂₁) is -3.83 dB on 1 GHz due to the lossy of FR-4 material conception and the return loss S₍₁₁₎ is -34.747 dB on 1 GHz, which concern that the simulation results was too close to the reality results.

Figures 6,7 below shows the device fabrication design and the laboratory measuring procedure.



Fig.6: The fabrication design of Band Pass Filter



Fig.7: The laboratory experimental for the fabricated Band Pass Filter

CONCLUSION

The designing of the proposed Band Pass Filter has been projected, designed and simulated. The result shows that the comeback return loss achieves below -20 dB for the whole band and most (S11) is at -3.83 dB. The look is compared with previous accomplishment that designed exploitation microstrip technology. The bandwidth achieves is wider compared with different style. The design of Band Pass Filter introduces more flattening and without ripple and very low cost comparing with the commercial one. The proposed fabrication design will be used in the future for detecting in lightning remote sensing.

REFERENCES

1. Ahmad, M. R., Esa, M. R. M., Cooray, V., & Dutkiewicz, E. (2014). Interference from cloud-to-ground and cloud flashes in wireless communication system. *Electric Power Systems Research*, 113(September 2010), 237–246. <https://doi.org/10.1016/j.epsr.2014.03.022>
2. Al-Amin, R., Omar, M., & Chowdhury, F. (2016). Design and Simulation of Fifth Order Band-Pass Filter for S Band. *Iject*, 7(1), 56–60. Retrieved from <http://www.iject.org/vol71/1/13-md-rasheduzzaman-al-amin.pdf>
3. Al-Shaikhli, T. R., Zakaria, Z., Ahmad, B. H., Ahmad, M. R., Murtdha, M., & Al-Taweel, M. H. (2018). Design of 1GHz low noise amplifier for microwave applications. *Journal of Advanced Research in*

- Dynamical and Control Systems, 10(7 Special Issue), 647–651. [https://doi.org/10.1002/\(SICI\)1521-3765\(19990104\)5:1<198::AID-CHEM198>3.0.CO;2-5](https://doi.org/10.1002/(SICI)1521-3765(19990104)5:1<198::AID-CHEM198>3.0.CO;2-5)
4. Al-Shaikhli, T. R., Ahmad, B. H., & Al-Taweel, M. H. (2020). Experimental Study on Electromagnetic Metal Forming (EMF). *International Journal of Advanced Science and Technology*, Vol. 29, No. 8, 5150-5159
 5. Ahmad, B. H., Al-Shaikhli, T. R., Hassan, N., Ibrahim, A. M., Lim, P. E., & Nordin, N. S. (2021). A review on echo and phase inverted scanning in acoustic microscopy for failure analysis. *Przełąd Elektrotechniczny*, Vol. 1(3), 11-16
 6. Chen, J., & Liao, S. S. (2016). Design of Compact Printed 2 . 4 GHz Band-pass filter using LC resonator, 377–379.
 7. Garg, A., Pratap, B., & Gupta, D. (2016). Design of parallel coupled line band pass filter. *Proceedings - 2016 2nd International Conference on Computational Intelligence and Communication Technology, CICT 2016*, 452–454. <https://doi.org/10.1109/CICT.2016.96>
 8. Moitra, S., Nath, A., Rout, S. R., & Bhowmik, P. S. (2017). Band pass filter design using half mode substrate integrated waveguide (HMSIW) with periodically loaded F-EBG structures. *2016 IEEE Students' Technology Symposium, TechSym 2016*, 192–195. <https://doi.org/10.1109/TechSym.2016.7872680>
 9. Moore, B. C. J. (2015). *An Introduction to Lightning*. New York. <https://doi.org/10.1017/CBO9780511623806>
 10. Taghizadeh, M., Moloudian, G., & Rouzbeh, A. R. (2015). Design and Simulation of Band-Pass Filter using Micro-Strip Lines. *International Journal of Computer Science and Mobile Computing*, 4(11), 331–337.
 11. Vaghela, D. C., Sisodia, A. K., & Prabhakar, N. M. (2015). Design , Simulation and Development of Bandpass Filter at 2 . 5 GHz, 3(2), 1202–1209.
 12. Verma, A., Srivastava, D., & Engineering, C. (2015). Designing , Simulation and Fabrication of Hairpin Band Pass Filter Using, 2(11), 195–198.